

EH-3030A940-A120

Feature

- Black EMC package
- High radiation intensity
- Suitable for SMT assembly
- High output power at 940nm

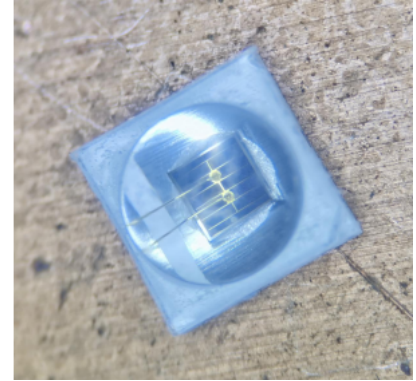

Applications

- Infrared illumination for CCTV
- Infrared data transmission
- Infrared illumination for night

Device Selection Guide

Type	Product	Size	Manufacturer
High Power IR LED	EH-3030A940-A120	3.0*3.0 *2.02mm	EHAOAN

Package Dimensions/尺寸參數

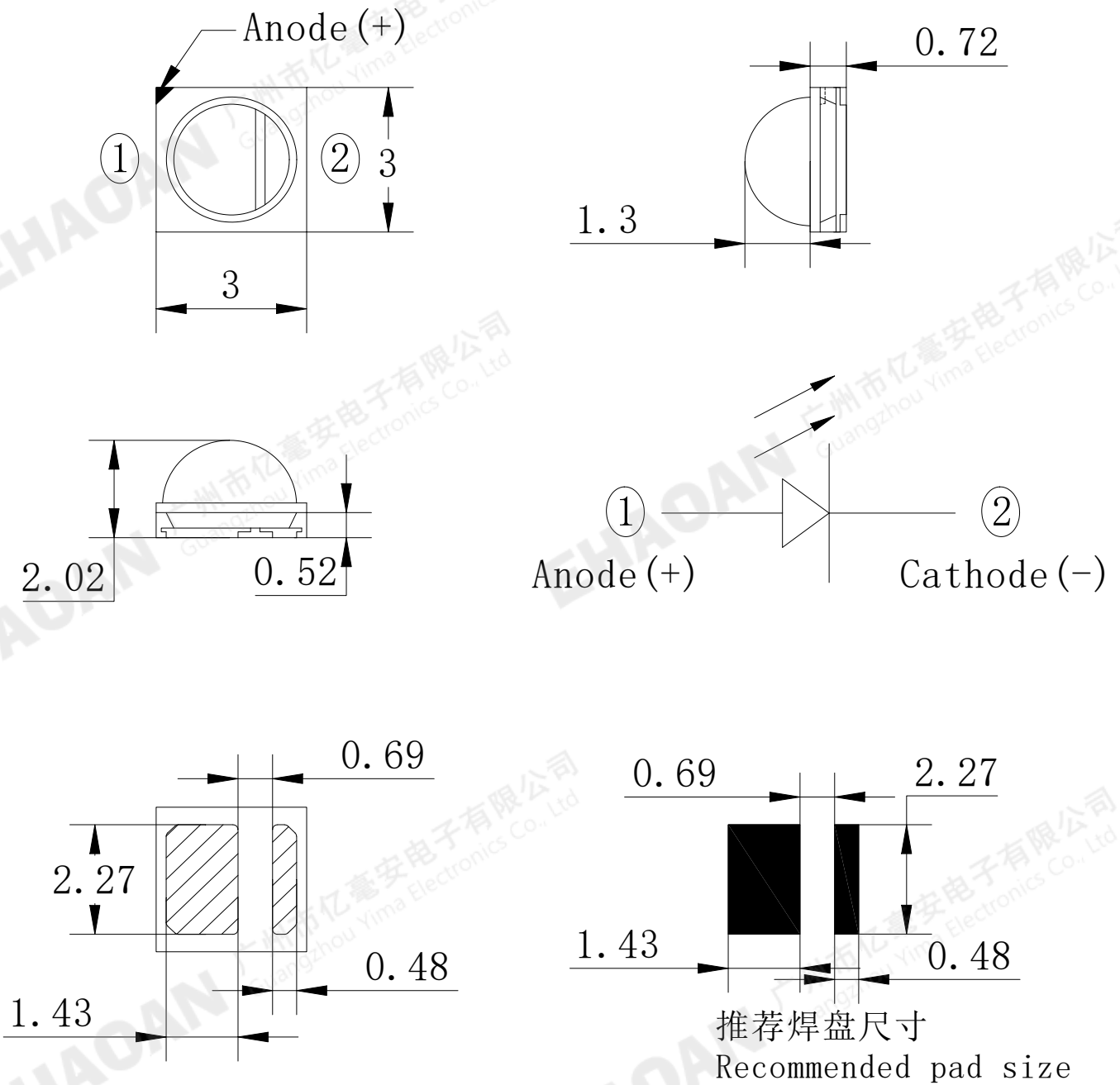

備註 Notes :

- 1.所有尺寸均為 All dimensions are in millimeters : mm
- 2.尺寸誤差 Dimension error:0.1mm (0.004inch)

Absolute Maximum Ratings / 最大限度參數值(Ta=25°C)

參數名稱 Parameter	符號 Symbol	最大額定值 Rating	單位 Unit
正向電流 Forward Current	I _F	≤700	mA
反向電壓 Reverse voltage	V _R	5	V
耗散功率 Power Dissipation	P _d	1.0	W
工作溫度 Operating Temperature	T _{sop}	-30 ~ +85	°C
存儲溫度 Storage Temperature	T _{stg}	-40 ~ +100	°C
回流焊溫度 Circle solder Temperature	T _{sol}	245°C for 5sec	°C

Opto-Electrical Specification / 主要光電參數

參數名稱 Parameter	符號 Symbol	最小值 Min.	標準值 Typ.	最大值 Max.	單位 Units	測試條件 Conditions
輻射通量 Radiant flux	P _o	110	---	160	mW	I _F =350mA
視角 View Angle	2θ _{1/2}	---	120	---	deg	I _F =350mA
波長 Wavelength	λ _p	930	940	960	nm	I _F =350mA
半波寬 Half wave width	Δλ	---	35	---	nm	I _F =350mA
正向電壓 Forward Voltage	V _F	---	1.6	1.8	V	I _F =350mA
反向電流 Reverse current	I _R	---	---	10	μA	V _R =5V

Typical Characteristics Curves/曲線參數

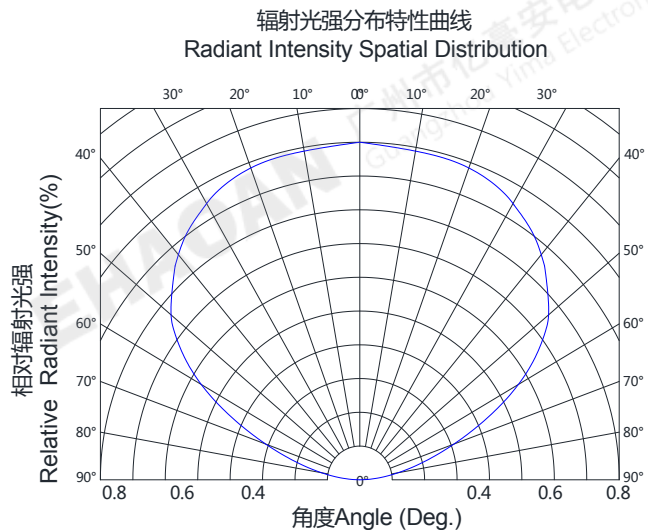
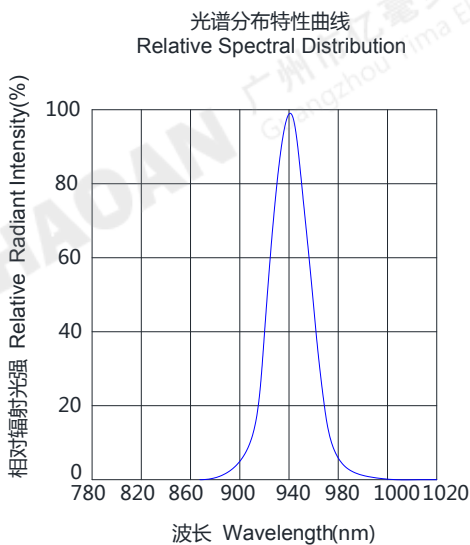
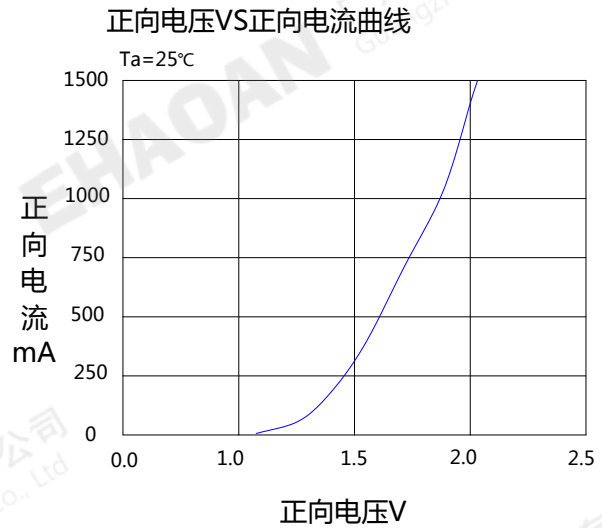
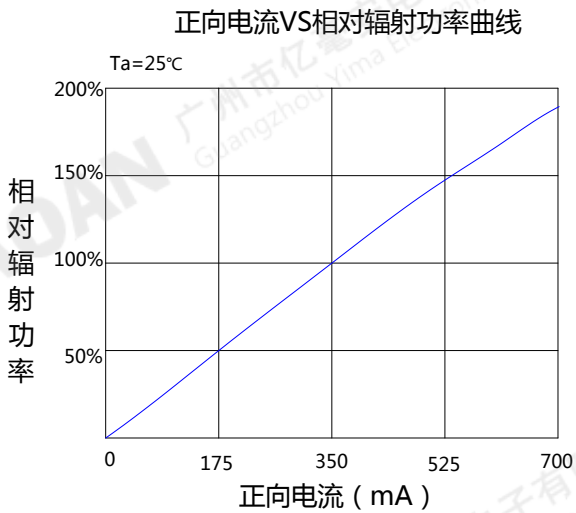
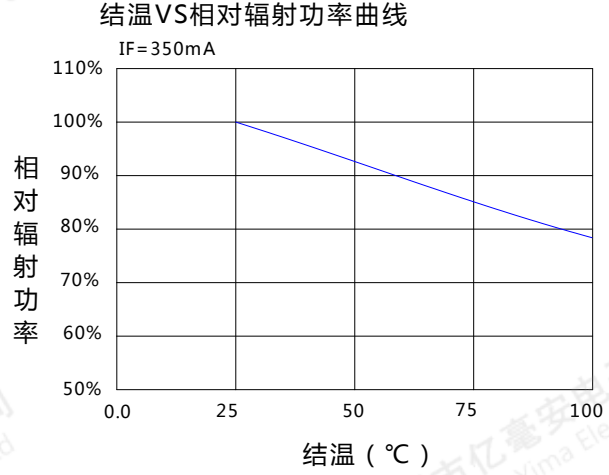
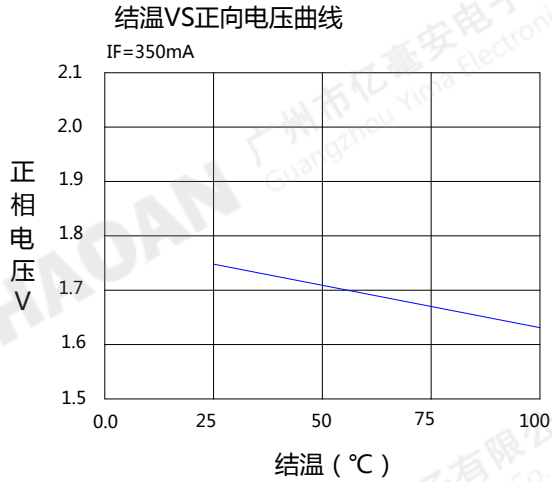

Reliability Test/可靠性試驗

测试项目 Test Parameter	参考标准 Reference Criterion	测试条件 Test Condition	时间 Time	数量 Quantity	接受/拒收 Ac/Re
回流焊 Resistance to Soldering Heat	JESD22-B106	Temp:245°C max T=10sec	3 times	22Pcs	0/1
温度循环 thermocycling	JESD22-A104	100°C±5°C 30min.	100 Cycles	22Pcs	0/1
高温保存 High Temperature storage	JESD22-A103	Temp:100°C ±5°C	1000Hrs	22Pcs	0/1
低温保存 Low Temperature storage	JESD22-A119	Temp:-40°C ±5°C	1000Hrs	22Pcs	0/1
常温通电 Operating Life Test	JESD22-A108	Ta=25°C±5°C IF=1000mA	1000Hrs	22Pcs	0/1
高温高湿通电 High Temperature High Humidity	JESD22-A101	85°C±5°C/85% RH IF=1000mA	1000Hrs	22Pcs	0/1

Packaging Specifications/包裝規格

Dimensions of Tape /載帶尺寸(Unit: mm)

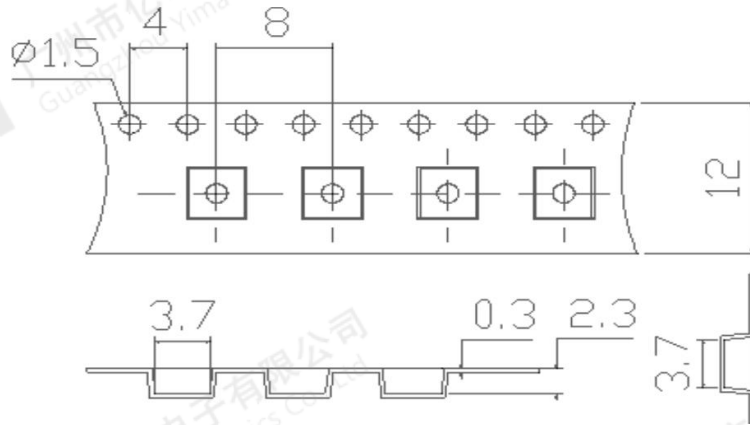

Feeding Direction/送料方向

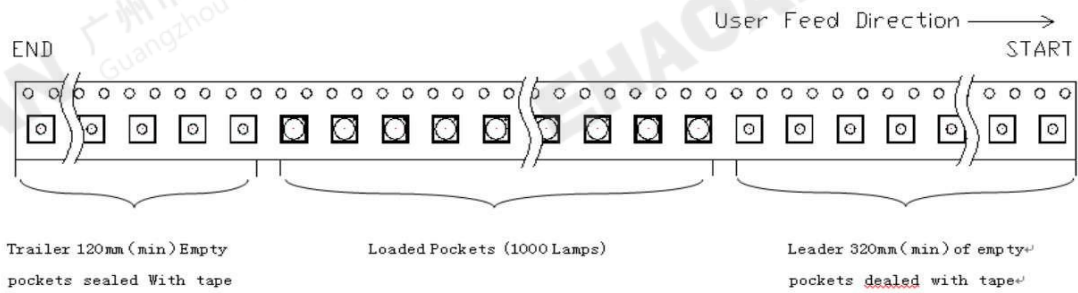

Dimensions of Reel /捲軸尺寸(Unit: mm)

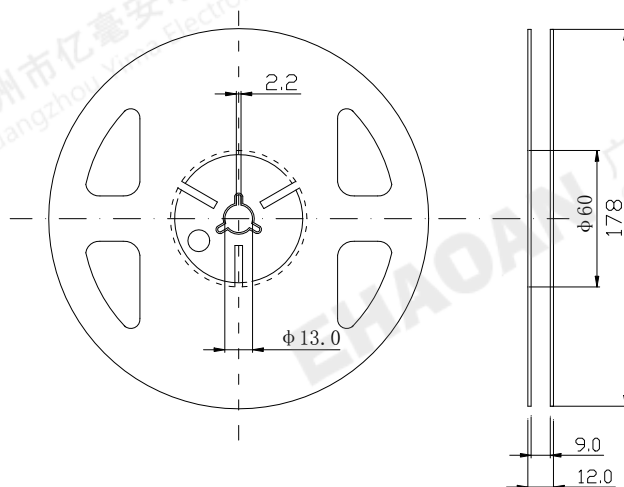

备注: 每卷数量 4000PCS

Notes: 4000 pcs/ reel

Notes/注意事项

■ 回流焊说明 Reflow soldering instruction :

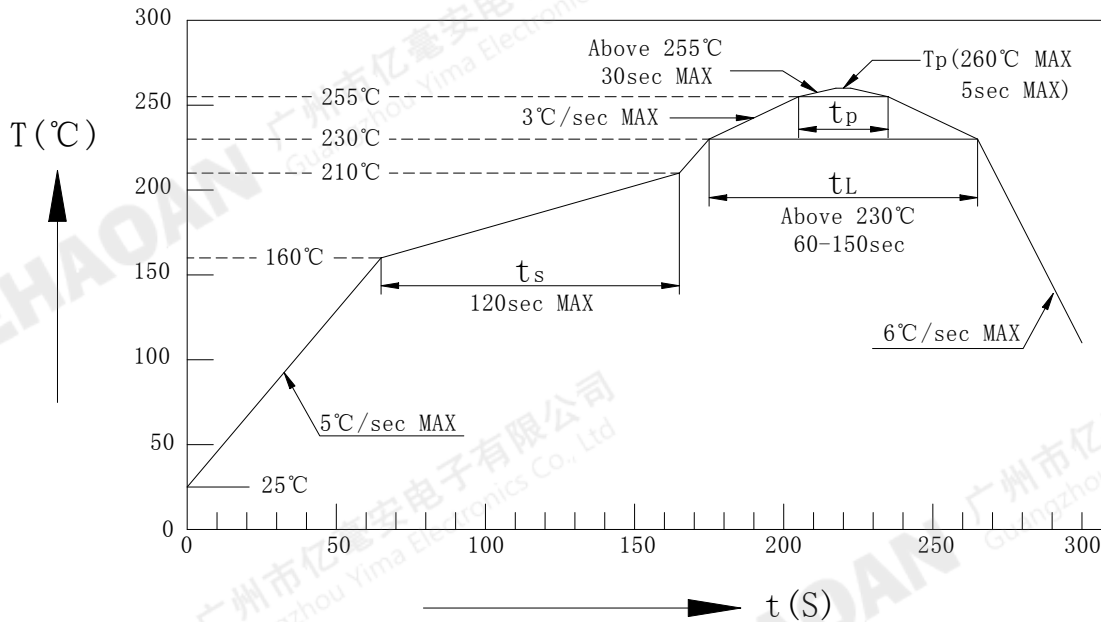

备注：回流焊最多只能进行一次，在回流焊接升温过程中，请不要对 LED 施加任何压力。在焊接完成后，待产品温度下降到室温之后，再进行其他处理。Note: Re-flow soldering can only be operated one time at most. During the temperature ramp-up, do not put any pressure. After soldering completed, do not make any processing until the product temperature ramp down to room temperature.

■ **处理防护措施 Treatment & Protection measures :**

焊接 Soldering (包括手动和回流焊 including manual operation & re-flow soldering)

人手焊接时，烙铁的温度必须保持在 300°C以下，且每个电极只能进行一次焊接，每次焊接的持续时间不能超过 3 秒。因 LED 尺寸较小，采用手工焊接较难管控焊接温度及加锡时间的一致性，且易破坏灯体结构，严重时可能造成 LED 失效，请尽量使用回流焊机台作业。

The temperature of soldering iron must keep under 300°C during hand soldering. Each electrode can only be soldered one time and the duration could not be over 3sec. It is very hard to control the soldering temperature and make tin time uniformly via manual operation due to LED small size. In addition, it is easy to damage LED structure even caused LED losing efficacy. Therefore, using re-flow soldering machine for operation is better.

存储 Storage

本产品使用密封防潮抗静电铝箔袋包封并附有干燥剂。搬运过程中应尽量避免挤压，刺破包装袋的情况发生。同时为避免产品受潮引发可靠性失效的问题，需做好 LED 产品焊接前的储存与防潮措施。

开封前，LED 产品在温度不高于 30°C，湿度不高于 60%RH 的环境中保存时间为 90 天。

开封后，LED 产品必须在温度不高于 30°C，湿度不高于 60%RH 的环境中，且在 24 小时内使用完。

开启后如发现湿度卡超过 10% 需低温除湿处理 75°C/12h。

Our products packed by aluminum foil bag attaching dryer that can be sealed, moisture-proof and anti-static electricity. Please try to avoid pressing or puncturing bag during carrying. At the same time, please be ready for storage and moisture-proof measures before soldering to be keep LED away from dampness that may cause reliability losing efficacy.

Before opening, The storage time of LED products is 90 days in the environment of temperature not higher than 30°C and humidity not higher than 60% RH.

After opening, LED products must be used up within 24 hours in an environment where the temperature is not higher than 30°C and the humidity is not higher than 60% RH. If it is found that the humidity card exceeds 10% after opening, it needs low temperature dehumidification treatment at 75°C/12h.

静电防护 Electrostatic protection

静电和电涌会导致产品特性发生改变，例如正向电压降低等，情况严重甚至会损毁产品。所以对于整个工序（生产，测试，包装等）与 LED 直接接触的员工都要做好防止和消除静电的措施。

所有相关的设备和机器都应该正确接地。接地交流电阻小于 1.0 欧姆，工作台上需垫表面电阻 106-109 欧姆的桌垫。

在容易产生静电的环境和设备上，还必须安装离子风扇。作业过程中，操作员需使用防静电手环，防静电垫子，防静电工作服，工作鞋，手套，防静电容器等。

Static and surge will change product property, such as lower forward voltage and damage products. Therefore, the workers in direct contact with LED in production processes must take some treatment to prevent and eliminate static electricity.

All related equipment and machine should be grounded correctly. Grounded AC resistance should less than 1.0Ω and the working table need to be applied the mat with surface resistance 106-109 Ω .

It must to fix ion fan for the environment that easy to generate static electricity and also on the equipment. During operation, workers need to use anti-static wrist strap, anti-static mat, anti-static clothing, anti-static shoes, anti-static gloves, anti-static container and etc.

其他事项 Others

LED 产品的树脂封装部分相当脆弱，请勿用坚硬，尖锐的物体刮擦封装树脂部分。用镊子夹取 LED 时也要十分小心。请勿直接用手去直接拿去 LED 产品。直接用手去拿取 LED 产品不但会污染 LED 封装树脂表面，也可能由于静电等因素导致 LED 产品性能的改变。请勿对 LED 产品施加过度压力，特别当 LED 处于高温状态小（例如在回流焊焊接过程中），过度的压力可能直接影响封装内部的芯片及金线。LED 工作环境及 LED 适配的材料中硫元素及化合物成分不可超过 100PPM。不可将模组材料堆积在一起，它可能会损坏内部电路。不可用在 PH<7 的酸性场所。The resin package part of LED product is quite fragile. Thus, not to scrap this part by used hard or sharp objects. Please not to take LED products directly by hand. Otherwise, it will not only contaminate LED package resin surface, but also may change LED performance due to static electricity or other factors. Do not apply excessive pressure on LED products when LED is in a state of high temperature, such as during re-flow soldering. Excessive pressure may impact the inner chip and gold thread directly. In LED working environment and compound composition of the LED, the sulfur element not be more than 100PPM. Do not pile up the module material and it may damage inner circuit. Do not apply on acid sites that PH<7.